

Surface Mount, 3-Electrode Gas Discharge Tube B3G8SS Series

Descriptions

The Gas Discharge Tube (GDT) operates as a symmetrical voltage-dependent switch. Features as very high surge current handling capability, very high insulation resistance and ultra-low capacitance meet almost perfectly all requirements made on a protective element.

The B3G8SS Series are 3-pole GDTs designed for protection of power lines. Low insertion loss is also perfectly suited to broadband equipment applications.

Features

- 3-electrode arrester
- Very small size
- Rugged Ceramic-Metal construction
- Stable performance over life
- Extremely low capacitance ($\leq 1.5\text{pF}$)
- High insulation resistance

Applications

- PCI cards
- Modem
- Splitter
- Line cards
- Applications with limited space

Product Dimensions (mm)

Dimension

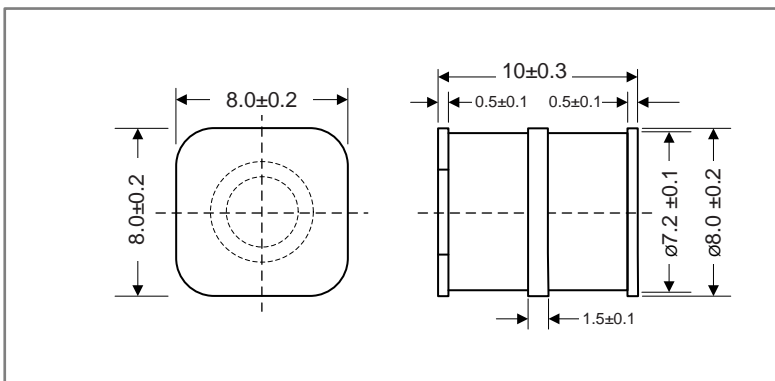

Recommended Pad Size

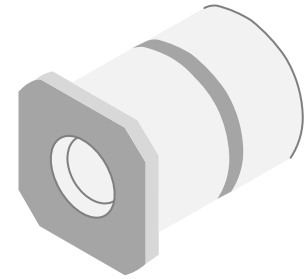
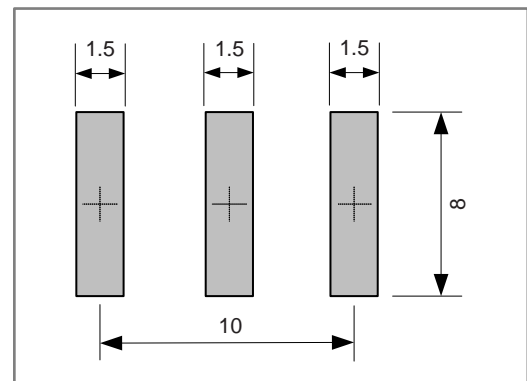

Part Numbering System

B 3 G 8 S S-900M-E10

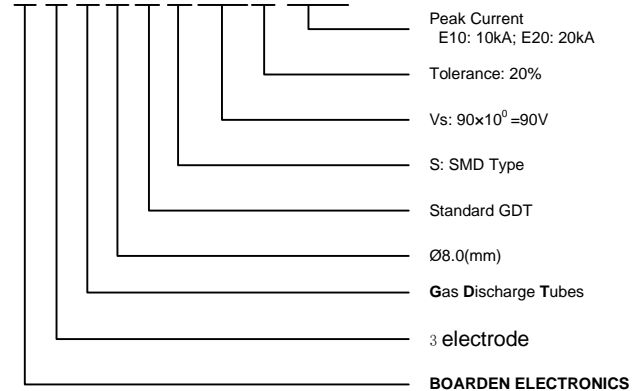

Order information

Device	Qualities	Size
B3G8SS Series	300/R	13 Inch

Electrical Characteristics (TA=25°C unless otherwise noted)

Part Number	V _s ^{1),2)} @100V/s	V _{ss}		IMDC			ACDC	IR ³⁾	C
		100V/μs	1kV/μs	8/20μs ±5 times	8/20μs 1 time	10/1000μs 300 times	@50Hz 1s 5 times		1MHz
		Max.	Max.	Nom.	Max.	Min.	Nom.	Min	Max
	V	V	V	kA	kA	A	A	GΩ	pF
B3G8SS-750M-E10	75±20%	500	600	10	20	200	10	1	1.5
B3G8SS-900M-E10	90±20%	500	600	10	20	200	10	1	1.5
B3G8SS-151M-E10	150±20%	500	600	10	20	200	10	1	1.5
B3G8SS-231M-E10	230±20%	600	700	10	20	200	10	1	1.5
B3G8SS-251M-E10	250±20%	600	700	10	20	200	10	1	1.5
B3G8SS-301M-E10	300±20%	750	850	10	20	200	10	1	1.5
B3G8SS-351M-E10	350±20%	800	900	10	20	200	10	1	1.5
B3G8SS-401M-E10	400±20%	850	950	10	20	200	10	1	1.5
B3G8SS-421M-E10	420±20%	850	950	10	20	200	10	1	1.5
B3G8SS-471M-E10	470±20%	900	1000	10	20	200	10	1	1.5
B3G8SS-601M-E10	600±20%	1000	1200	10	20	200	10	1	1.5
B3G8SS-801M-E10	800±20%	1300	1400	10	20	200	10	1	1.5
Glow voltage at 10mA.....				~60V					
Arc voltage at 1A.....				~10V					
Glow to Arc transition current.....				~1.0A					
Weight.....				~2.0g					
Operation and storage temperature.....				-40 ~ +90°C					
Climatic category (IEC 60068-1).....				40/90/21					
Marking, Blue.....				□ S xxx yy xxx -Nominal voltage; yy -Production year					

1) At delivery AQL 0.65 level II, DIN ISO 2859

2) In ionized mode

3) Insulation resistance measuring voltage: 75V at 25Vdc; 90~150V at 50Vdc; other at 100Vdc

Terms in accordance with ITU-T Rec.K.12, IEC 61643-311, GB/T 9043

Electrical Characteristics (TA=25°C unless otherwise noted)

Part Number	V _s ^{1),2)} @100V/s	V _{ss}		IMDC			ACDC	IR ³⁾	C
		100V/μs	1kV/μs	8/20μs ±5 times	8/20μs 1 time	10/1000μs 300 times	@50Hz 1s 5 times		1MHz
		Max.	Max.	Nom.	Max.	Min.	Nom.	Min	Max
		V	V	V	kA	kA	A	A	GΩ
B3G8SS-750M-E20	75±20%	500	600	20	25	200	20	1	1.5
B3G8SS-900M-E20	90±20%	500	600	20	25	200	20	1	1.5
B3G8SS-151M-E20	150±20%	500	600	20	25	200	20	1	1.5
B3G8SS-231M-E20	230±20%	600	700	20	25	200	20	1	1.5
B3G8SS-251M-E20	250±20%	600	700	20	25	200	20	1	1.5
B3G8SS-301M-E20	300±20%	750	850	20	25	200	20	1	1.5
B3G8SS-351M-E20	350±20%	800	900	20	25	200	20	1	1.5
B3G8SS-401M-E20	400±20%	850	950	20	25	200	20	1	1.5
B3G8SS-421M-E20	420±20%	850	950	20	25	200	20	1	1.5
B3G8SS-471M-E20	470±20%	900	1000	20	25	200	20	1	1.5
B3G8SS-601M-E20	600±20%	1000	1200	20	25	200	20	1	1.5
B3G8SS-801M-E20	800±20%	1300	1400	20	25	200	20	1	1.5
Glow voltage at 10mA.....					~60V				
Arc voltage at 1A.....					~10V				
Glow to Arc transition current.....					~1.0A				
Weight.....					~2.0g				
Operation and storage temperature.....					-40 ~ +90°C				
Climatic category (IEC 60068-1).....					40/90/21				
Marking, Green.....					<input type="checkbox"/> S xxx yy xxx -Nominal voltage; yy -Production year				

1) At delivery AQL 0.65 level II, DIN ISO 2859

2) In ionized mode

3) Insulation resistance measuring voltage: 75V at 25Vdc; 90~150V at 50Vdc; other at 100Vdc

Terms in accordance with ITU-T Rec.K.12, IEC 61643-311, GB/T 9043

Soldering Parameters

Profile Feature	Lead-Free Assembly
Average Ramp-up Rate ($T_{S_{MAX}}$ to T_p) Average Ramp-down Rate (T_p to T_L)	3°C/second max. 6°C/second max.
Preheat • Temperature Min ($T_{S_{MIN}}$) • Temperature Max ($T_{S_{MAX}}$) • Time (t_s Preheat)	150°C 200°C 60-180 seconds
Time maintained above: • Temperature (T_L) • Time (t_L)	217°C 60-150 seconds
Peak/Classification Temperature • Temperature (T_p)	260 ^{+0/-5} °C
Time within 5°C of actual Peak Time (t_p)	20-40 seconds
Time 25°C to peak Temperature	8 minutes max
Do not exceed	280 °C

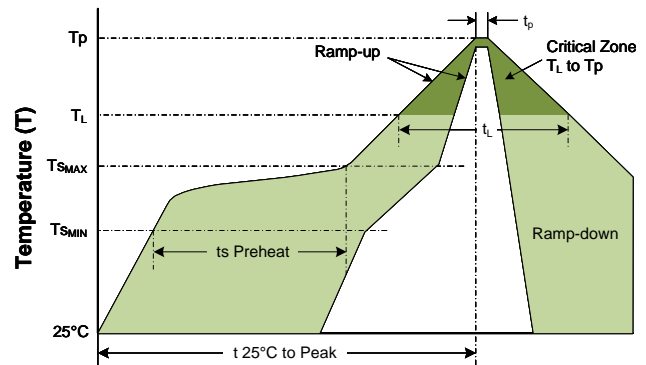

Flow/Wave Soldering (Solder Dipping)

Peak Temperature :	265 °C
Dipping Time :	10 seconds
Soldering :	1 time

Cautions and warnings

- Gas Discharge Tubes must not be operated directly in power supply networks.
- Gas Discharge Tubes may become hot in case of longer periods of current stress (danger of burning).
- Gas Discharge Tubes may be used only within their specified values. In case of overload, the head contacts may fail or the component may be destroyed.
- Damaged Gas Discharge Tubes must not be re-used.

© 2018 Boarden Electronics Ltd.
 Specifications are subject to change without notice.

Website: www.boarden.com.cn

Tel: 86-21-61401058

Fax: 86-21-61730538